

DESIGN PORTFOLIO

ZACH SPRAGGINS

ABOUT

University of Oregon
B.F.A Product Design

CONTACT

Phone - 2145160109
Email - zach.spraggins@gmail.com

NAME BRAND

An everyday jacket inspired by the different styles and personalities in a big city for every occasion

THE DESIGN



ISSUE SPRING 2024



NAME BFA PRODUCT DESIGN CAPSTONE BRAND



ZACH SPRAGGINS
CREATIVE DIRECTIONS

MEET MARK

THE NEW AGED URBAN DWELLER



CREATIVE



TIMELESS



TRAVELLER



EXPRESSIVE



INDIVIDUAL



SOCIAL



DAY IN THE LIFE

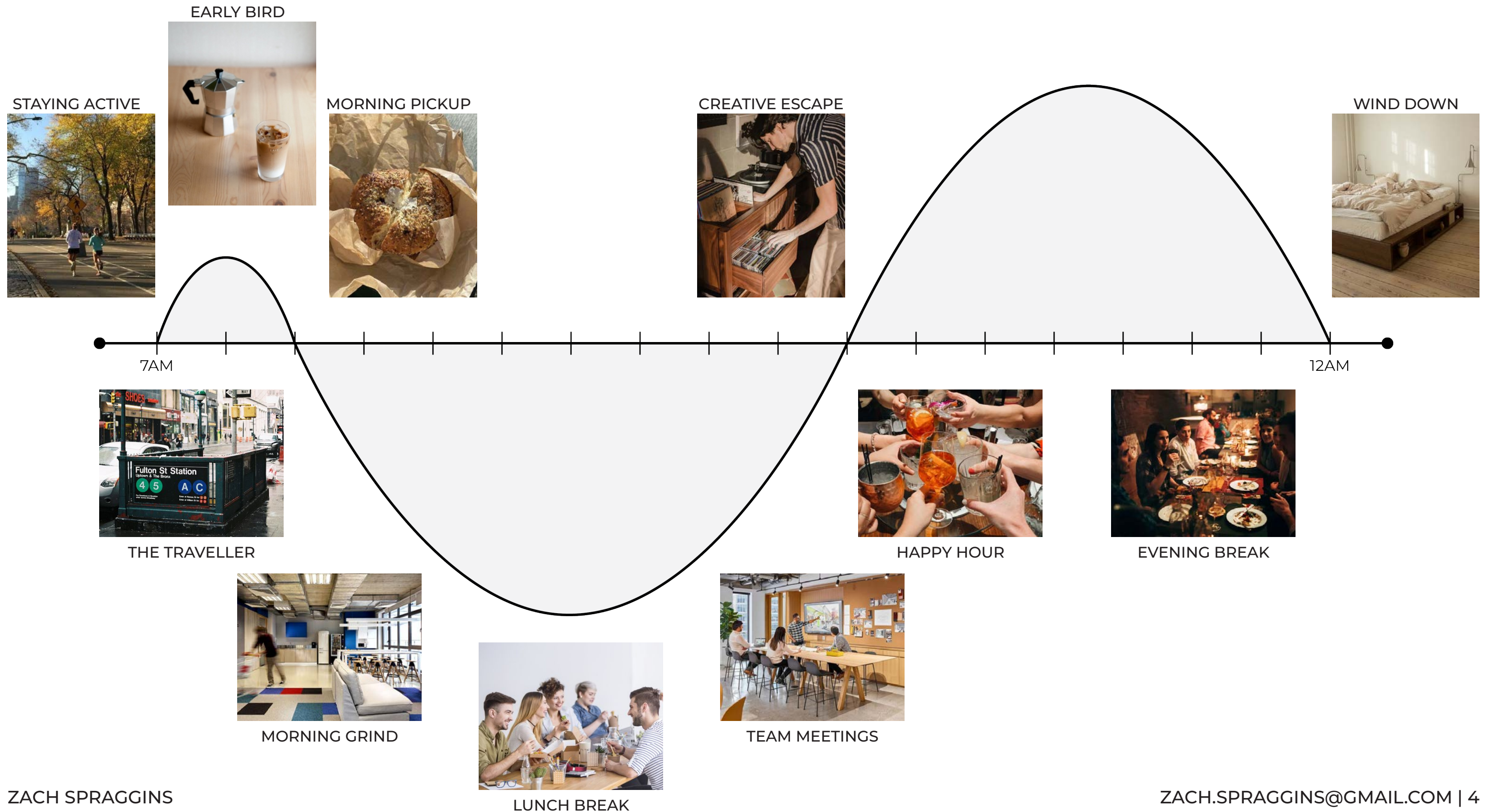

CONCRETE JUNGLE

INTO THE CITY OF CREATIVE EXPRESSION

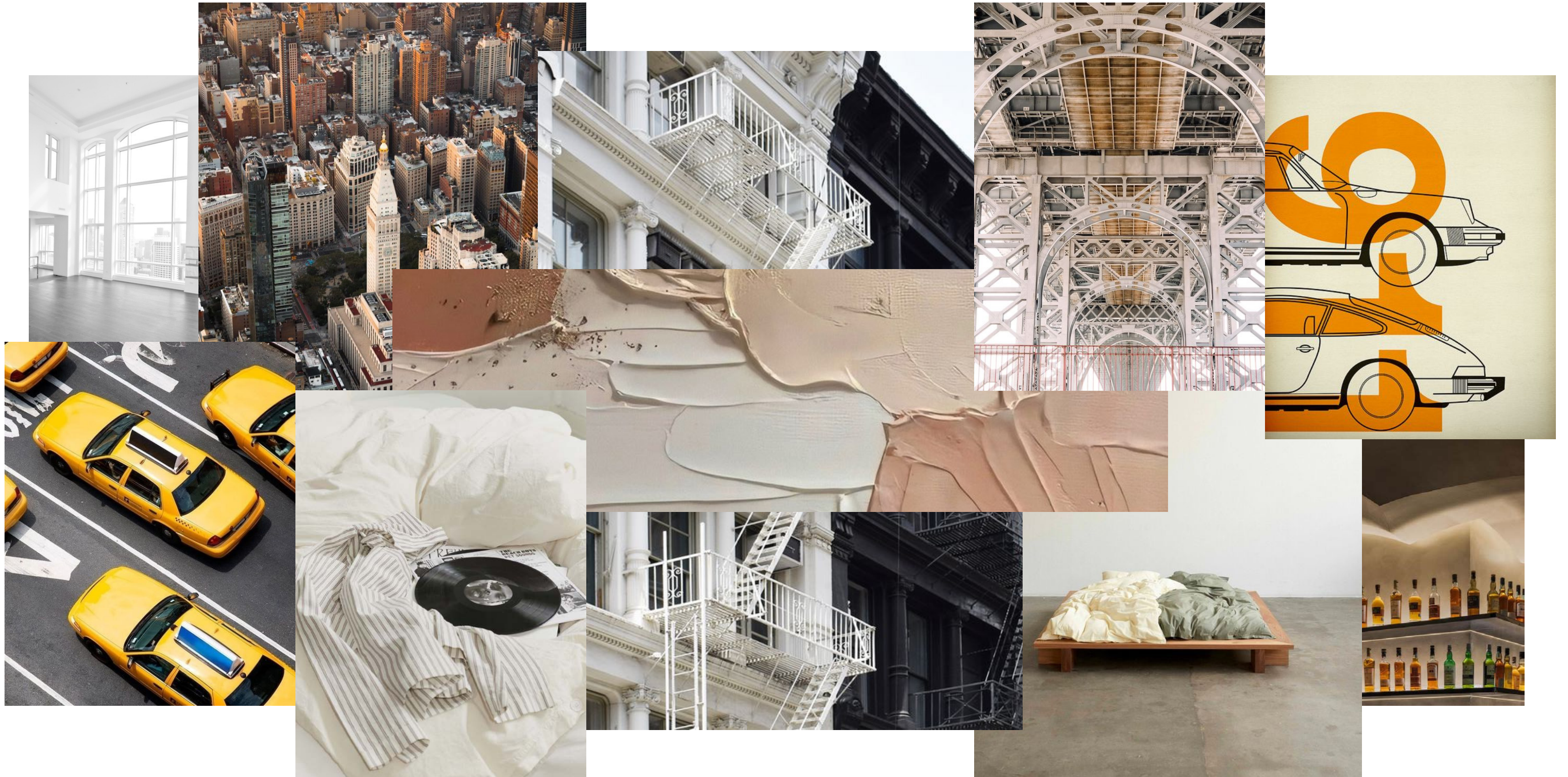

THE COLORS

CLASSICS WITH POPS OF SEASONAL COLOR

BLACK

NAVY

BEIGE

YELLOW

WHITE



IDEATION



THE DETAILS



TWO WAY ZIPPER FRONT



HIDDEN INSEAM POCKETS



INVISIBLE ZIPPER CHEST POCKETS



EXTENDED BACK SHIRT HEM



SPLIT PANELING



VELCRO SLEEVE CUFF CLOSURE

MODERN MILITARY

A collection inspired by the vintage military aesthetic presented into a modern everyday wear uniform style

THE DESIGN



MILITARY VINTAGE REVIVAL

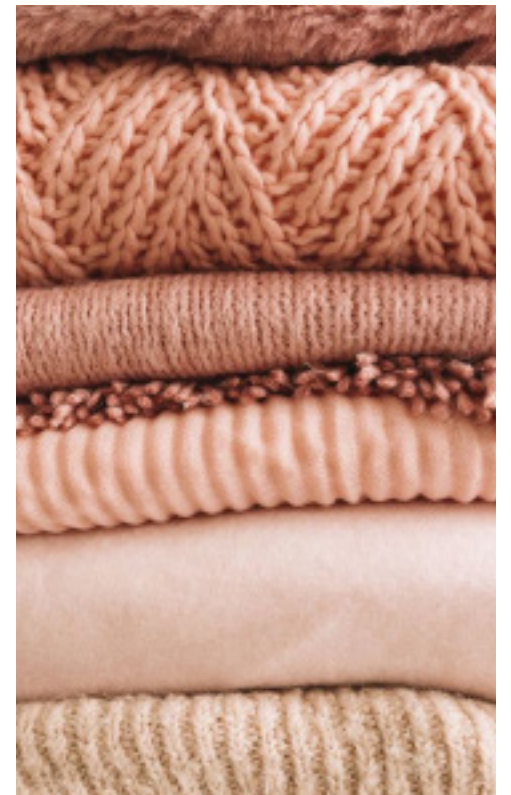

THE LINEART

Zach Spraggins	Style: Technical Shirt	Fall 2022
	Date: OCT 2022	Page: 2/6

FRONT



Zach Spraggins	Style: Military Pant	Fall 2022
	Date: OCT 2022	Page: 2/6

FRONT

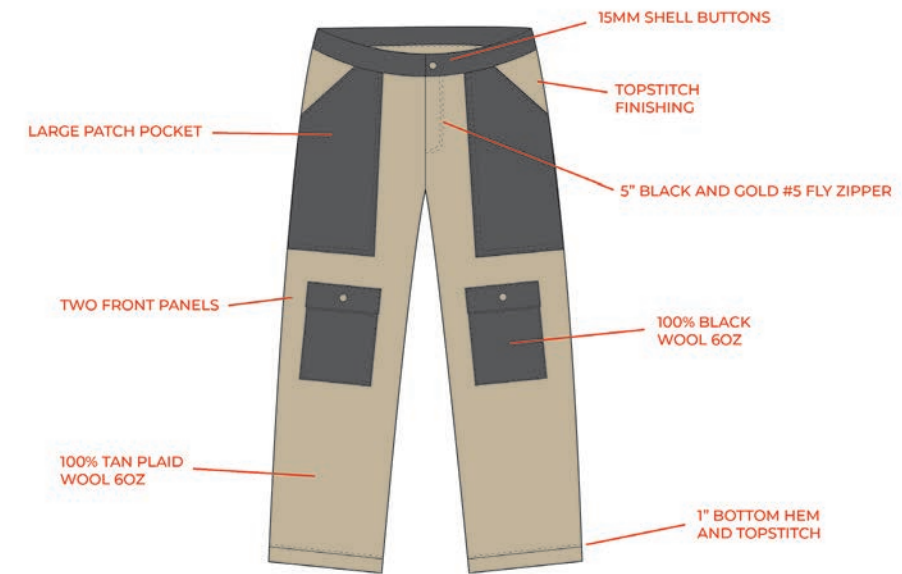

Zach Spraggins	Style: Bag	Fall 2022
	Date: NOV 2022	Page: 2/6

FRONT

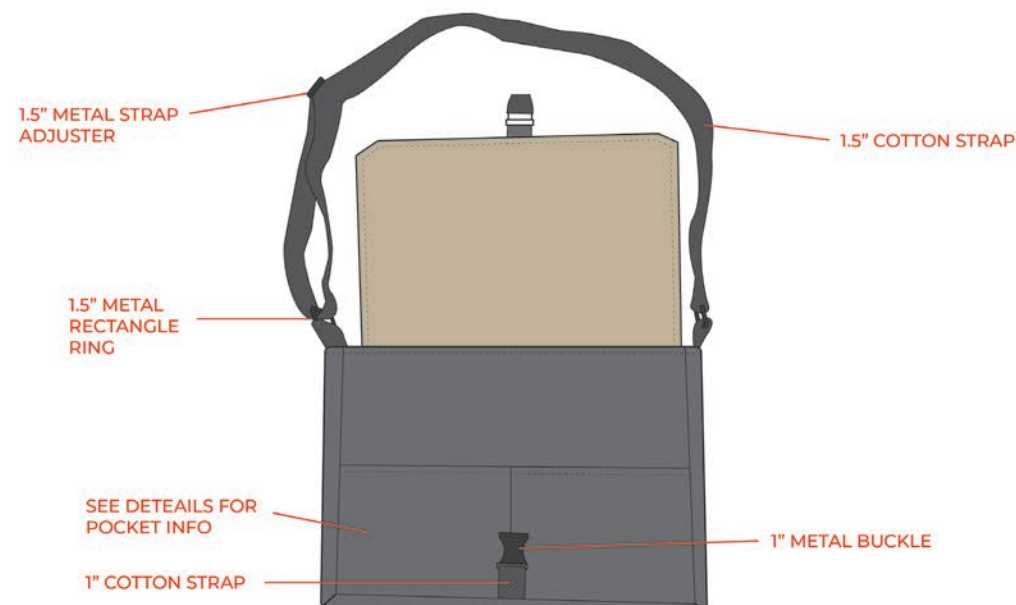

Zach Spraggins	Style: Hat	Fall 2022
	Date: NOV 2022	Page: 1/3

SIDE 1

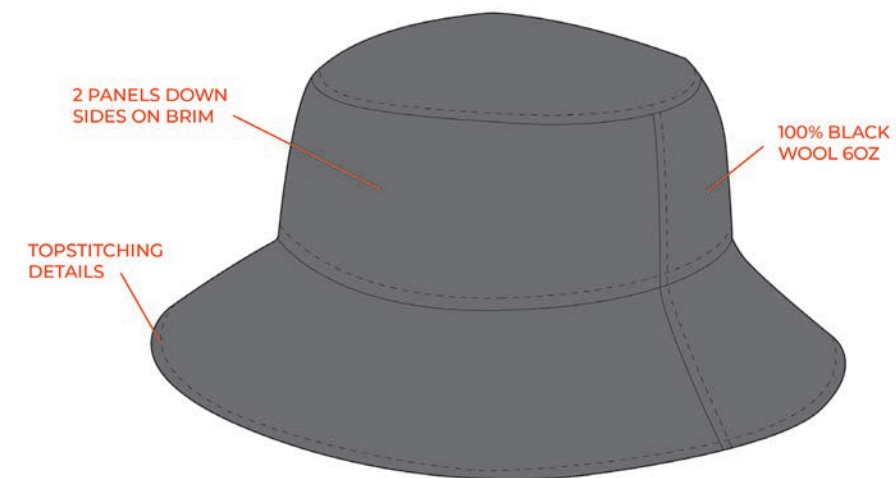

THE PIECES



THE DETAILS



EVERYDAY BAG

An everyday daily carry bag that mixes a luxury travel aesthetic with outdoor technical features

THE DESIGN



DURABLE LUXURY



THE LINEART

Zach Spraggins	BAG	WINTER 2023
	DAILY CARRY	Page: 2/11

FRONT

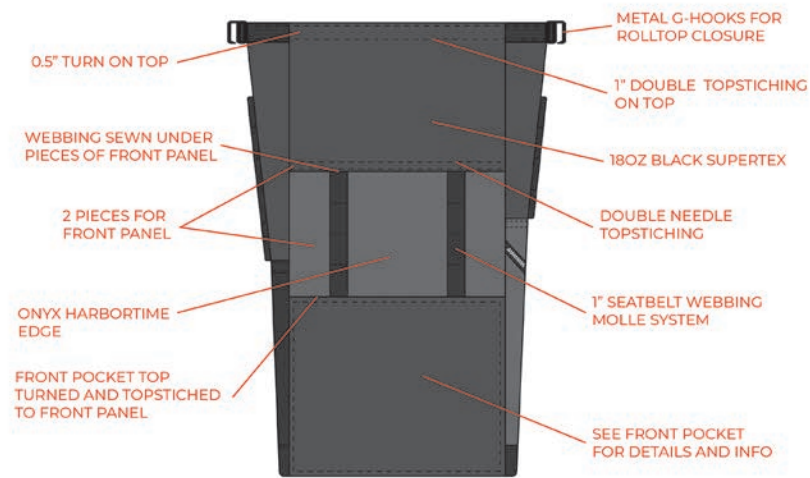

Zach Spraggins	BAG	WINTER 2023
	DAILY CARRY	Page: 3/11

BACK

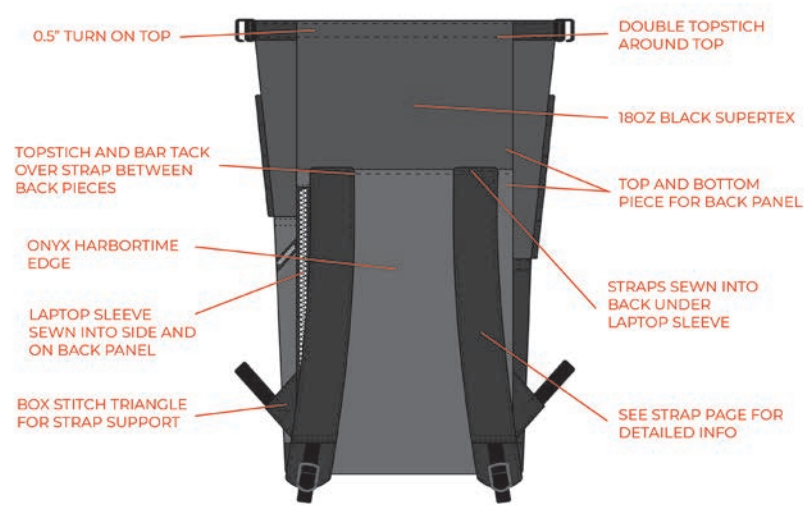

Zach Spraggins	BAG	WINTER 2023
	DAILY CARRY	Page: 6/11

INTERIOR FRONT

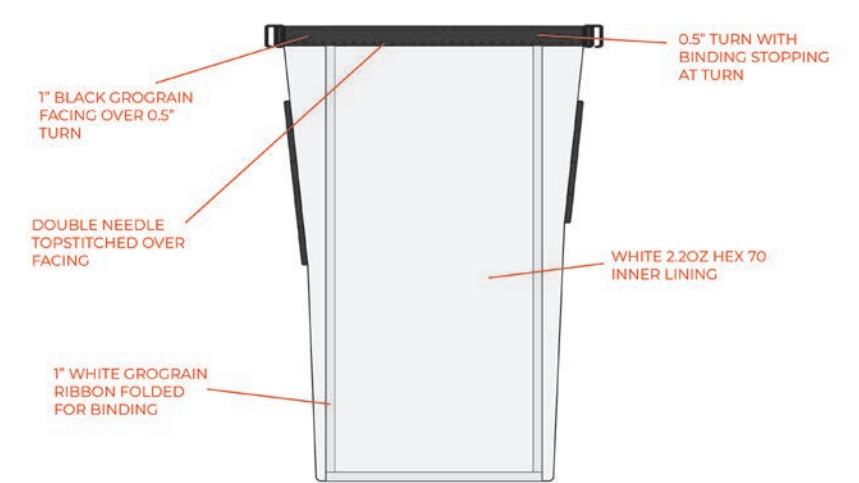

Zach Spraggins	BAG	WINTER 2023
	DAILY CARRY	Page: 8/11

STRAP

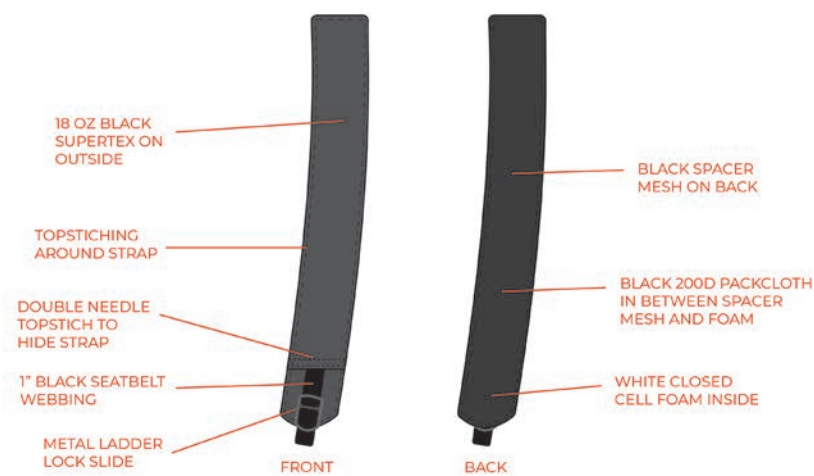

Zach Spraggins	BAG	WINTER 2023
	DAILY CARRY	Page: 10/11

SIDE POCKETS

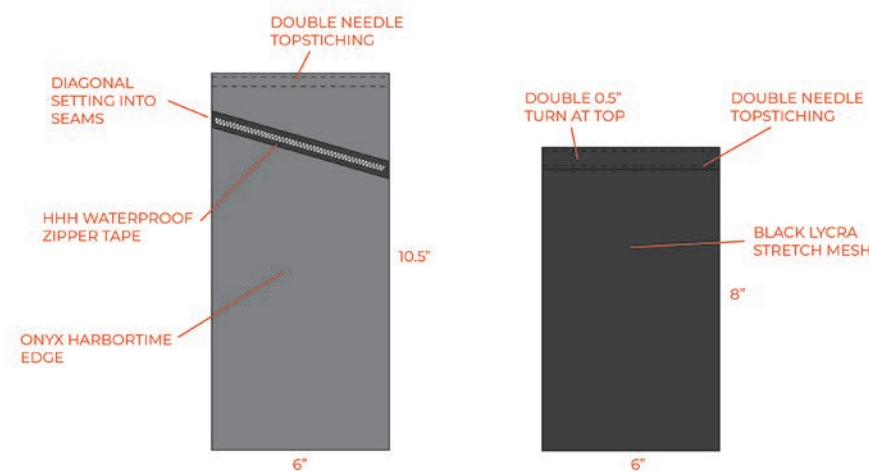

Zach Spraggins	BAG	WINTER 2023
	DAILY CARRY	Page: 11/11

BOM

ITEM	DESCRIPTION	SUPPLIER	USAGE	SIZE / QUANTITY	COL 1
BODY FABRIC	SUPERTEX 18OZ	B&H UPHOLSTRY	EXTERIOR	1 YD	BLACK
BODY FABRIC	HARBORTIME EDGE	B&H UPHOLSTRY	EXTERIOR	1 YD	ONYX
LINING	200D PACKCLOTH	STUDIO	STRAP	.5 YD	BLACK
LINING	2.2OZ HEX 70	RIPSTOP BY THE ROLL	INTERIOR	1.5 YD	WHITE
WEBBING	NYLON WEBBING	AMAZON	DETAILS	1 YD	BLACK
THREAD	100% POLYESTER	STUDIO	ALL OVER	1 SPOOL	BLACK
THREAD	100% POLYESTER	STUDIO	INTERIOR BINDING	1 SPOOL	WHITE
G-HOOK	METAL	SEND CUT SEND	CLOSURE	2	BLACK
ZIPPER TAPE	HHH WATERPROOF COIL ZIPPER	RIPSTOP BY THE ROLL	POCKET	1 YD	BLACK
ZIPPER PULL	HHH COIL SLIDER	RIPSTOP BY THE ROLL	POCKET	3	BLACK
MESH	SPECTRA STRETCH MESH	STUDIO	POCKET	.25 YD	BLACK
FOAM	1/4" FOAM	STUDIO	BACK	.25 YD	WHITE
FOAM	1/16" FOAM	B&H UPHOLSTRY	STRAP	.25 YD	WHITE
LADDER LOCK	METAL 1" LADDER LOCK STRAP SLIDERS	AMAZON	STRAP	2	GUNMETAL
FACING	GROGRAIN RIBBON	AMAZON	INTERIOR FACING	.5 YD	BLACK
BINDING	GROGRAIN RIBBON	RIPSTOP BY THE ROLL	BINDING	5 YD	WHITE

THE PROTOTYPES



THE DETAILS

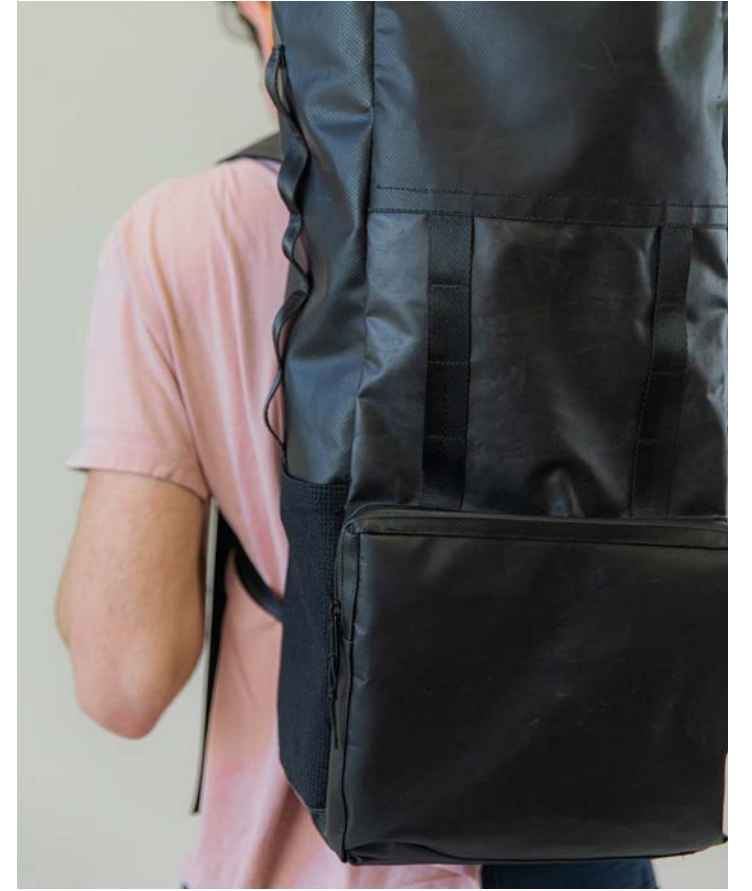

KOKOMO SHOE

A lifestyle training shoe designed for the Vuori brand with performance details meant for the boutique fitness and active lifestyle

THE DESIGN



THE BRAND IDENTITY



2015 Vuori is founded by Joe Kudla



Based out of Southern California in Encinitas



Inspired by the counter surf and skate culture



Grows from mens to womens in 2018



Minimal aesthetic and branding across the products



Instagram influencers and a large social media presence



Following the "Boutique Fitness" and athlesure trend



No current footwear line being made in the company

THE BRIEF

RETAIL - \$149.99

FOB - \$39

MARGIN - 70%

SEASON - SS24

SILHOUETTE - Low

MATERIAL INDICATOR - TNU

DESIGNER - Zach Spraggins

END USE - Boutique Fitness Lifestyle

UNIQUE SELLING POINTS / FEATURES

- Cushioned foam for comfort and training
- Breathable knit upper
- External heel support
- Easy pull on heel tab
- Secure and breathable lightweight throat

CONSUMER PROFILE

- Southern California resident
- Attend workout classes and hikes
- Active everyday lifestyle
- Goes to local farmers market
- Surfs and is a part of the culture

COMPETITOR MODELS



Lululemon
Chargefeel 2
\$138

- 9.5mm Heel drop
- Dual-density midsole
- Pressure mapped outsole
- Smooth Liner
- Design mirrors how you workout



ON
Cloudnova
\$159.99

- 14mm Heel drop
- External TPU heel stabilizer
- Connected Cloudtec outsole
- Mesh upper
- Inner sock construction + padded heel



Nike
Air Max 270
\$160

- Lightweight and airy knit fabric upper
- Max air unit in heel
- Stretch inner sleeve and bootie construction
- Soft and comfortable foam midsole
- Heel pull tab

BOUTIQUE FITNESS

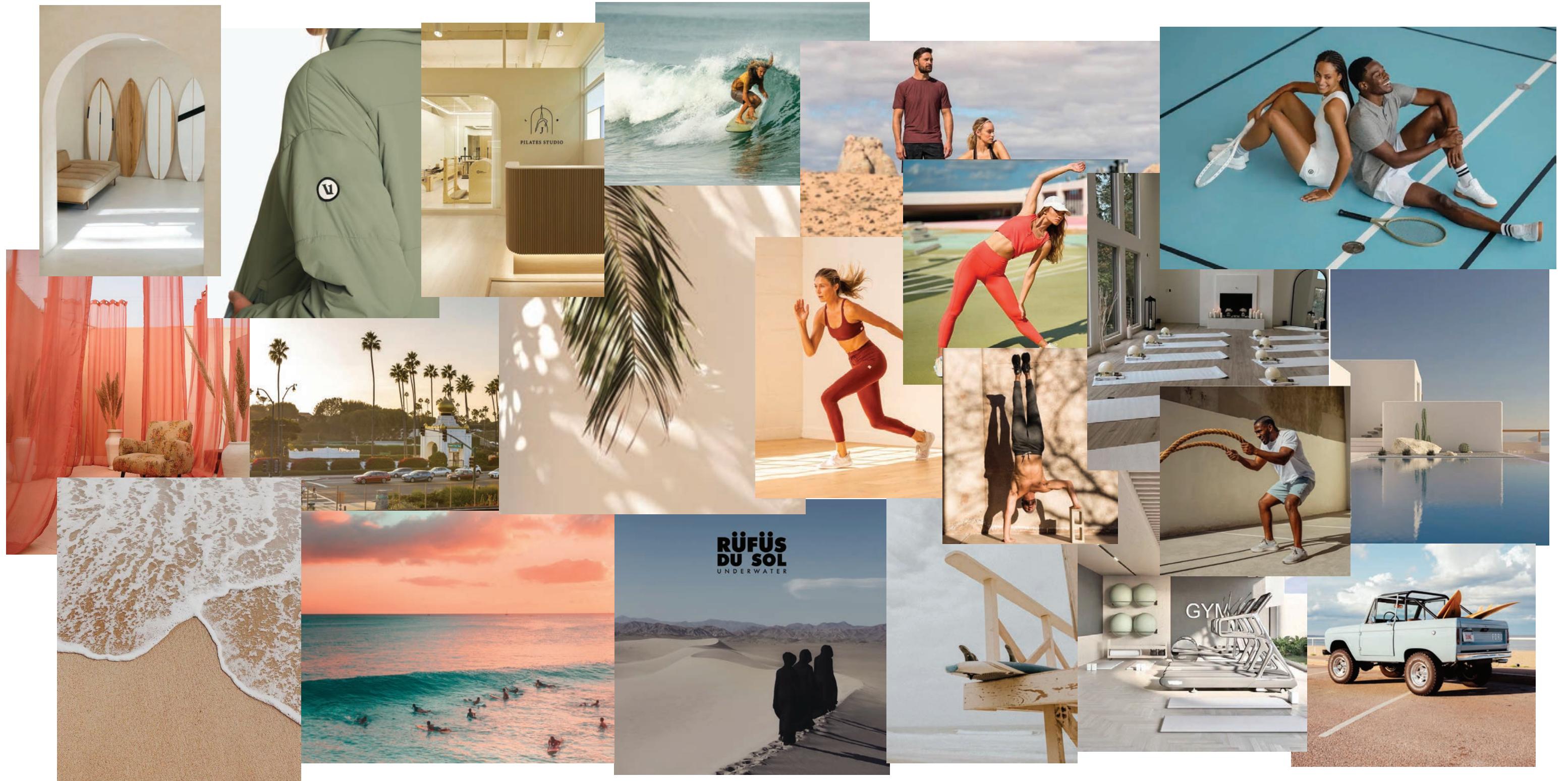

CFM / COLOR

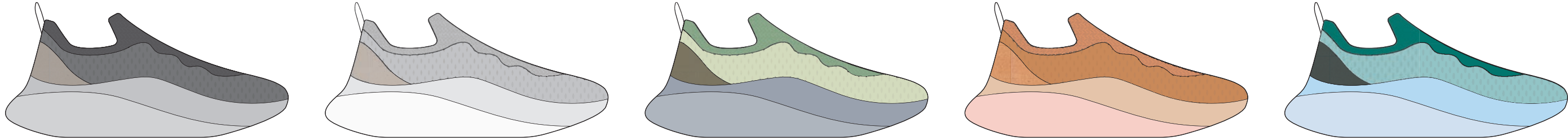

THE TECHNICAL

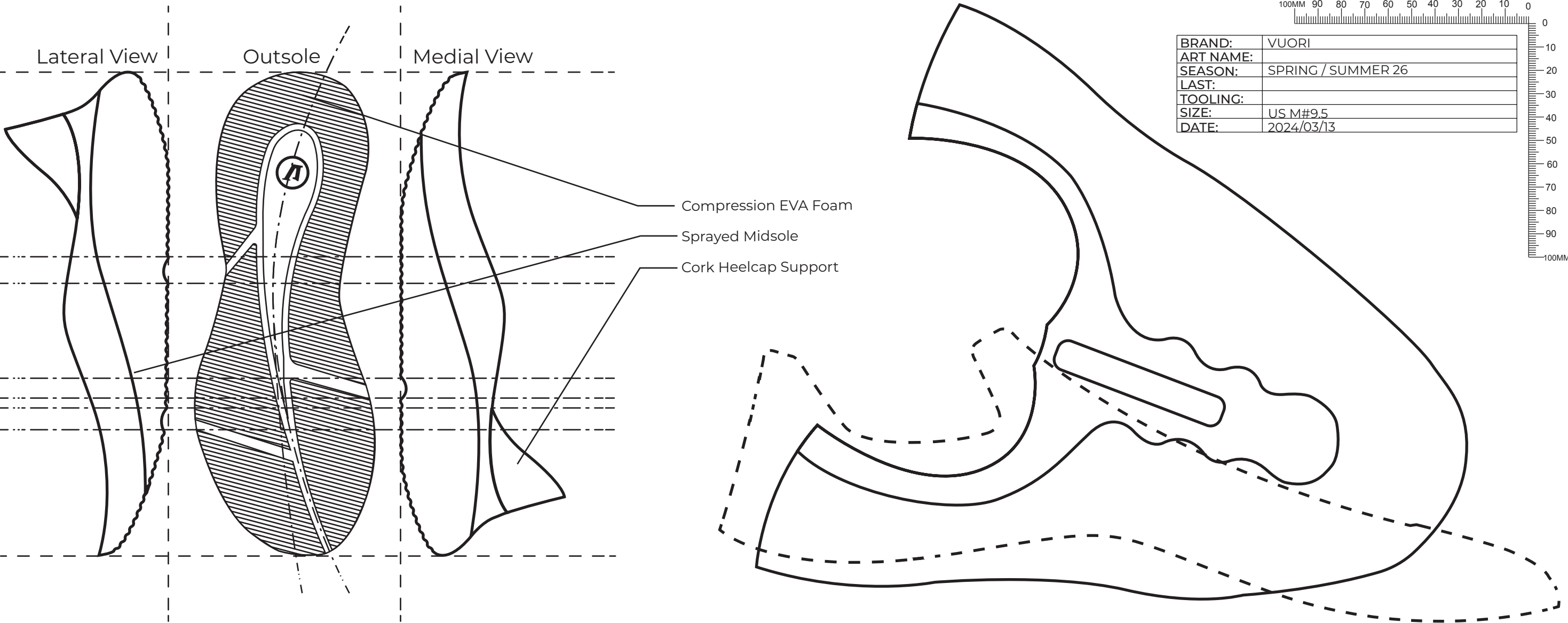

THE RENDERS



THANK YOU

DESIGN PORTFOLIO BY ZACH SPRAGGINS

ABOUT

University of Oregon
B.F.A Product Design

CONTACT

Phone - 2145160109
Email - zach.spraggins@gmail.com